

Vacuum to 10^{-11} mbar
 Winding Temperature -270 to $+300$ °C
 Radiation Hardened to 10^6 J/kg

Extreme Environment Stepper Motors

Environments

Phytron offers different categories of extreme environment stepper motors:

VSS-FV, VSH-FV

Fine Vacuum to 10^{-3} hPa (10^{-3} mbar)
 Winding temperature range -20 °C to 150 °C
 Radiation resistance 10 J/kg

VSS-HV, VSH-HV

High Vacuum to 10^{-7} hPa (10^{-7} mbar)
 Winding temperature range -20 °C to 200 °C
 Radiation resistance 10^2 J/kg

VSS-UHV, VSH-UHV

Ultra High Vacuum to 10^{-11} hPa (10^{-11} mbar)
 Winding temperature range -20 °C to 300 °C
 Radiation resistance 10^6 J/kg

VSS-UHVC, VSH-UHVC

Cryo

Ultra High Vacuum to 10^{-11} hPa (10^{-11} mbar)
 Winding temperature range -270 °C to 40 °C
 Radiation resistance 10^6 J/kg

Customized design

Modified versions of the type VSS/VSH stepper motors:

Climatic applications
 Reduced magnetic emission
 Aggressive environment operation
 Clean room applications
 to clean room class 100

Preparing the VSS/VSH Stepper Motors

The VSS/VSH series of Phytron stepper motors are designed to be used inside vacuum chambers. This eliminates the use of motion feed throughs that generate particulates.

Since the stepper motor is relatively simple in design, it can be adapted to operate in extreme physical environments with a few modifications. Under normal conditions, only the bearings are subject to wear.

For extreme environment applications, special windings, bearings and lubricants are used, as well as special insulating material and special adhesive.

To accommodate most extreme environmental conditions, Phytron VSS/VSH stepper motors are provided in different grades. Each grade covers a vacuum rating, a temperature range and a radiation level.

Assembly, cleaning and conditioning of the Phytron VSS/VSH stepper motors results in a low outgassing rate which makes Phytron the reliable choice for all the extreme environment applications.

Optional

Double shaft
 VGPL low backlash gear
 KTC thermocouple to monitor winding temperature in the range of -40 °C to 300 °C
 Pt100 resistor sensor to monitor winding temperature in the range of -200 °C to $+300$ °C
 Couplings
 Customized constructions
 Motors with spindle
 Motors with hollow shaft etc.



Technical Information

- Two-phase stepper motors
- Holding torque from 3.4 mNm to 9.9 Nm
- Diameters from 19 to 125 mm
- Standard number of steps 200
Optional 72, 500
- Step accuracy 3% for 1.8° stepper motor and 5% for 0.72° stepper motor
- Design voltage
size 19 to 57: $42 V_{DC}$
size 65 to 125: $200 V_{DC}$
- Protection class
IP 00 for vacuum version
IP 40 for temperature and radiation version (not for vacuum applications)
- Standard number of leads: 4
optional 5, 6 or 8
- Outgassing holes to avoid pockets of trapped gas

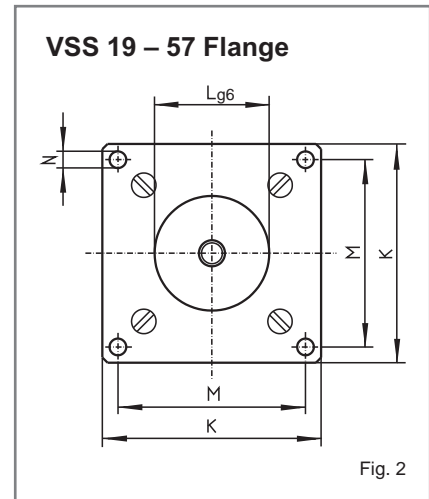
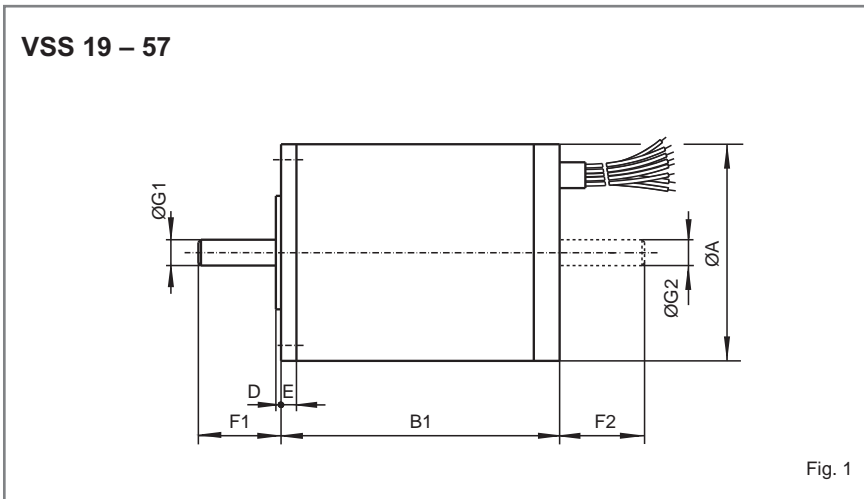

VSS 19 – 57		Dimensions in mm											
Size	Type	A	B1	D	E	F1	F2	G1 ¹⁾	G2 ¹⁾	K	L	M	N
19	VSS 19	19	26.5	1	2	7.5	6.5	2.5	2.5	19	10	16	M2.5
25	VSS 25	25	31	1	2.5	9.5	8.5	3	3	25	14	21.5	2.2
32	VSS 32	32	38.5	1	3	11	10	4	4	32	18	27	2.8
	VSS 33	32	57.5	1	3	11	10	4	4	32	18	27	2.8
42	VSS 42	42	54	1	3	16	15	5	4	42	22	36	3.2
	VSS 43	42	69	1	3	16	15	5	4	42	22	36	3.2
52	VSS 52	52	65	1.5	3.5	17.5	16	6	4	52	28	44	4.3
56	VSS 57	56.4	74	1.5	4.5	22	20.5	6.35	6.35	60	38.1	47.15	5.2

¹⁾Shaft diameter tolerances: VSS 19 to 26: -0.005 to -0.009, from VSS 32: g5

Electrical and Mechanical Characteristics

Size	Standard Part 200 steps/rev.	Electrical Characteristics									Mechanical Characteristics					
		Parallel Windings ⁶⁾ (4 leads)			Series Windings (4 leads)			Unipolar Connection (5 or 6 leads)			4) 5) Holding Torque	5) Detent Torque	Rotor Inertia	Loads		Mass
		1) I/Ph	2) R/Ph	3) L/Ph	1) I/Ph	2) R/Ph	3) L/Ph	1) I/Ph	2) R/Ph	3) L/Ph				axial	radial	
		A	Ω	mH	A	Ω	mH	A	Ω	mH	mNm	mNm	kg cm ²	N	N	kg
19	VSS 19.200.0.3	0.3	6	2.2	0.15	24	8.8	0.21	12	2.2	3.4	0.9	0.0009	3	3	0.05
	VSS 19.200.0.6	0.6	2.1	0.55	0.3	8.4	2.2	0.42	4.2	0.55						
	VSS 19.200.1.2	1.2	0.625	0.15	0.6	2.5	0.6	0.84	1.25	0.15						
25	VSS 25.200.0.3	0.3	12	6	0.15	48	24	0.21	24	6	12	2	0.002	5	5	0.08
	VSS 25.200.0.6	0.6	3.25	1.5	0.3	13	6	0.42	6.5	1.5						
	VSS 25.200.1.2	1.2	0.95	0.4	0.6	3.8	1.6	0.84	1.9	0.4						
32	VSS 32.200.0.6	0.6	4.6	5.3	0.3	18.4	21.2	0.42	9.2	5.3	40	3	0.01	5	15	0.17
	VSS 32.200.1.2	1.2	1.25	1.2	0.6	5.0	4.8	0.84	2.5	1.2						
	VSS 32.200.2.5	2.5	0.3	0.3	1.25	1.2	1.2	1.75	0.6	0.3						
	VSS 33.200.0.6	0.6	7.5	9.3	0.3	30	37.2	0.42	15	9.3	68	3.3	0.018	5	15	0.26
	VSS 33.200.1.2	1.2	1.9	2.2	0.6	7.4	8.8	0.84	3.8	2.2						
	VSS 33.200.2.5	2.5	0.47	0.6	1.25	1.88	2.4	1.75	0.94	0.6						
42	VSS 42.200.0.6	0.6	7.25	11	0.3	29	44	0.42	14.5	11	120	5	0.045	20	40	0.35
	VSS 42.200.1.2	1.2	1.7	3	0.6	6.8	12	0.84	3.4	3						
	VSS 42.200.2.5	2.5	0.34	0.7	1.25	1.36	2.8	1.75	0.68	0.7						
	VSS 43.200.0.6	0.6	9.5	22.9	0.3	38	91.6	0.42	19	22.9	235	7	0.077	20	40	0.52
	VSS 43.200.1.2	1.2	2.6	5.2	0.6	10.4	20.8	0.84	5.2	5.2						
	VSS 43.200.2.5	2.5	0.5	1.2	1.25	2	4.8	1.75	1	1.2						
52	VSS 52.200.1.2	1.2	2.65	7	0.6	10.6	28	0.84	5.3	7	350	13	0.15	25	70	0.72
	VSS 52.200.2.5	2.5	0.6	1.6	1.25	2.4	6.4	1.75	1.2	1.6						
	VSS 52.200.5	5	0.165	0.4	2.5	0.66	1.6	3.5	0.33	0.4						
56	VSS 57.200.1.2	1.2	3.9	9.5	0.6	15.6	38	0.84	7.8	9.5	630	50	0.24	40	80	0.99
	VSS 57.200.2.5	2.5	0.8	2.4	1.25	3.2	9.6	1.75	1.6	2.4						
	VSS 57.200.5.0	5	0.25	0.8	2.5	1	3.2	3.5	0.5	0.8						

- 1) I/Ph: Phase current
 2) R/Ph: Phase resistance
 3) L/Ph: Phase inductance
 4) Holding torque in bipolar mode with parallel windings, 2 phases ON at rated current
 5) 7 mNm ~ 1 inoz
 6) Standard wiring at delivery (if no wiring mode was given in the order)
 Design voltage 42 V_{DC} (operation with SELV type supply)

Bold letters = Preferred types

Important:

All values given above were measured at room temperature of 25 °C (77 °F) and atmospheric pressure.

VSS 19 – 57 Stepper Motor with VGPL Low Backlash Gear

Stepper Motor with VGPL Gear

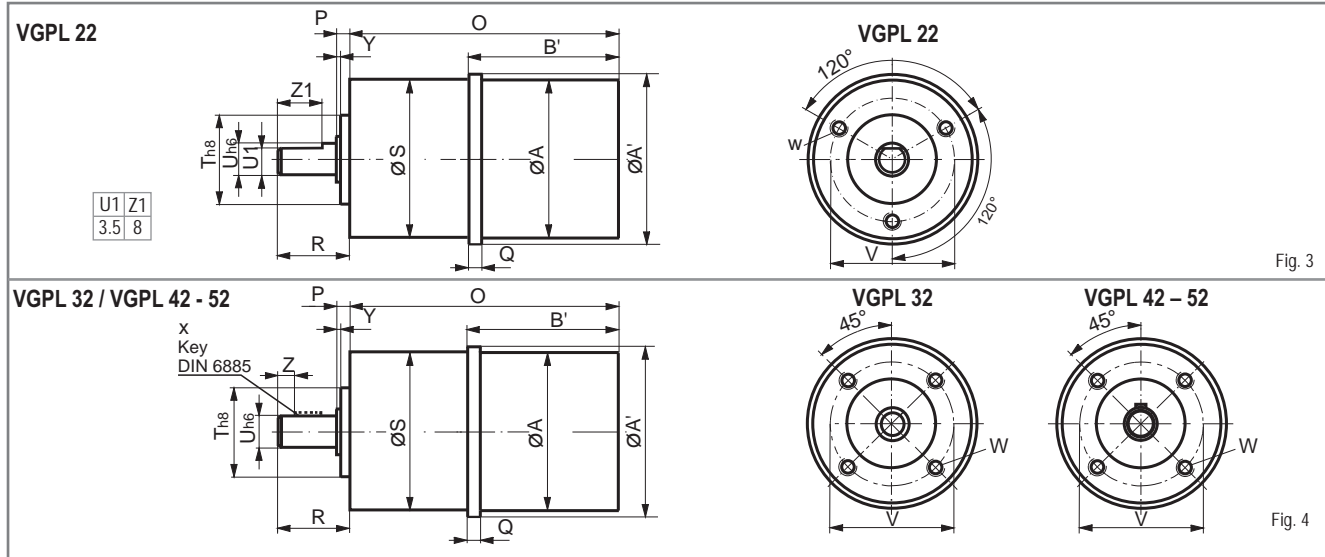

Gear	Stepper Motor	Dimensions in mm															Mass (motor + gear)				
																	stages				
		A	A'	B'	O			P	Q	R	S	T	U	V	W	X	Y	Z	kg		
VGPL 22	VSS 19	19	22	29	50	57	64	3	4.5	15	22	12	4	16	M 2.5x4	-	1	-	0.1	0.13	0.15
	VSS 25	25	25.5	33.5	53.5	60.5	67.5		5										0.13	0.15	0.18
VGPL 32	VSS 32	32	33	40.5	69.5	78.5	87.5	4	5	20	32	20	6	26	M 3x5	-	1	-	0.31	0.35	0.42
	VSS 33	32	33	59.5	88.5	97.5	106.5												0.39	0.44	0.51
VGPL 42	VSS 42	42	43	58	93	105.5	118	4	7	22.5	42	25	8	32	M 4x8	3x3x14	1	2.25	0.63	0.7	0.8
	VSS 43	42	43	73	108	120.5	133												0.8	0.85	0.93
VGPL 52	VSS 52	52	53	68.5	109.5	124	138.5	4	6.7	24	52	32	12	40	M 5x8	4x4x16	1	2	1.2	1.4	1.5
	VSS 57	56.4	57	78	119	133.5	148		9										1.4	1.5	1.6

Mechanical Characteristics																	
Gear	Stepper Motor	Stages	Gear 1) backlash	Max. torque	Gear inertia	Radial load ²⁾	Axial load	Efficiency	Reduction ratio								
			arc-min						Nm	kg cm ²	N	N	%				
VGPL 22	VSS 19 VSS 25	1	20'	0.1	0.005	30	24	94	4:1	5:1	7:1	35:1	49:1				
		2	35'	0.5	0.015									16:1	20:1	28:1	140:1
		3	50'	1.5	0.025												
VGPL 32	VSS 32 VSS 33	1	6'	0.4	0.025	80	65	94	4:1	4.5:1	5.2:1	6.25:1	8:1				
		2	10'	2	0.04									16:1	18:1	25:1	32:1
		3	15'	6	0.06												
VGPL 42	VSS 42 VSS 43	1	6'	0.7	0.05	150	120	94	4:1	5:1	6:1	120:1	184:1				
		2	10'	4	0.08									14:1	16:1	20:1	
		3	15'	12	0.12												56:1
VGPL 52	VSS 52 VSS 57	1	6'	1.5	0.1	250	200	94	4:1	4.5:1	5.2:1	6.25:1	8:1				
		2	10'	10	0.2									16:1	25:1	29:1	36:1
		3	15'	30	0.25												

1) no load

2) center of shaft

VSH 65 – 125 / Large Stepper Motors for Extreme Environments

VSH Stepper Motors

- Large stepper motors for extreme environments
- Available for FV, HV, UHV and UHVC vacuum classes
- Diameter 65 to 125 mm (2.56" to 4.92")
- Standard step angle 1.8° (200 steps/rev.)
- Standard 4-leads motor, parallel windings
- Holding torques of 0.86 Nm (123 in-oz) to 9.9 Nm (1410 in-oz)
- Design voltage 200 V_{DC} for operation with safe/double separation to mains

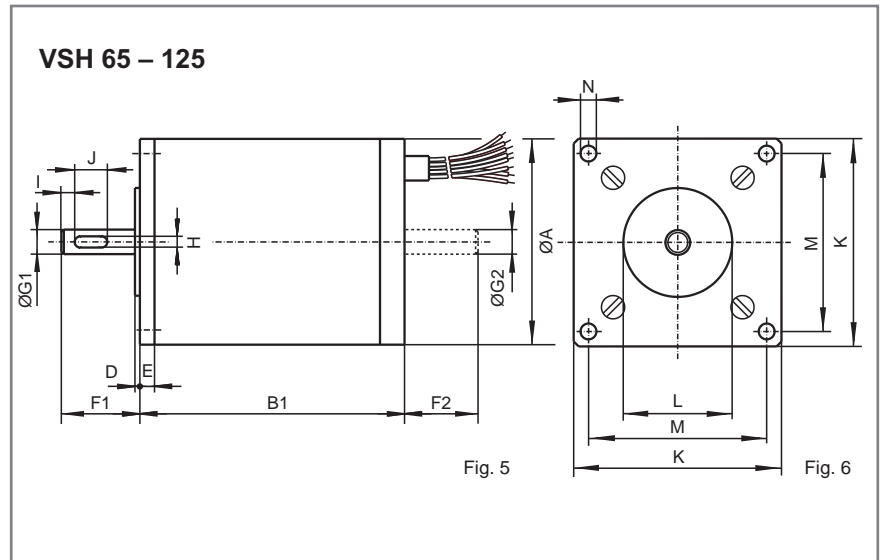

VSH 65 – 125		Dimensions in mm														
Size	Type	A	B1	D	E	F1	F2	G1 ⁶	G2 ⁶	H	I	J	K	L	M	N
65	VSH 65	65	81	1.5	5.5	23.5	22	8	7	2	3	14	65	40	55	5.2
80	VSH 80	80	100	2	7.5	27	25	10	9	3	2.5	20	80	50	68	6.4
100	VSH 100	100	125.5	2	8	32	30	12	12	4	3	22	100	60	86	6.4
125	VSH 125	125	156	3	9.5	34	31	14	14	5	3.5	22	125	60	108	8.4
		Electrical Characteristics									Mechanical Characteristics					
Type		Coil 1			Coil 2			Coil 3			4) 5)	5)	Loads			
		1) I/Ph	2) R/Ph	3) L/Ph	1) I/Ph	2) R/Ph	3) L/Ph	1) I/Ph	2) R/Ph	3) L/Ph	Holding torque	Detent torque	Rotor inertia	axial	radial	Mass
		A	Ω	mH	A	Ω	mH	A	Ω	mH	Nm	Nm	kg cm ²	N	N	kg
65	VSH 65	1.2	4.3	16.1	2.5	1.05	4	5	0.29	1.1	0.86	0.05	0.41	40	120	1.4
80	VSH 80	5	0.4	2.3	7.5	0.2	2	10	0.1	0.9	2	0.12	1.24	50	180	2.8
100	VSH 100	7.5	0.3	6.5	10	0.15	2.1	15	0.08	0.8	4.3	0.14	4.4	70	300	4.5
125	VSH 125	7.5	0.4	6	10	0.23	3	15	0.1	1.9	9.9	0.25	11.4	150	700	9.4
1) I/Ph: Phase current in the bipolar mode 2) R/Ph: Phase resistance 3) L/Ph: Phase inductance 4) Holding torque in bipolar mode with parallel windings, 2 phases ON at rated current 5) 7 mNm ~ 1 inoz 6) Shaft diameter tolerances: g5											Important: All values given above were measured at room temperature of 25 °C (77 °F) and atmospheric pressure.					
Bold letters = Preferred types, standard coil																

Torque Characteristics (T)

The curves correspond to the limit values of the drive torque as a function of the control pulses, for a motor voltage V.

The curves were plotted using a bipolar stepper motor driver in the half step mode.

Power Characteristics (P)

For each motor, the power at the motor shaft is plotted as a function of the frequency.

7 mNm ~ 1 oz-in

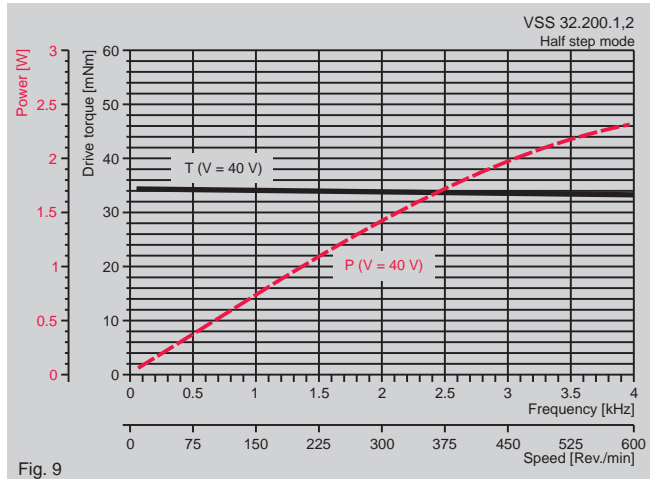

Fig. 9

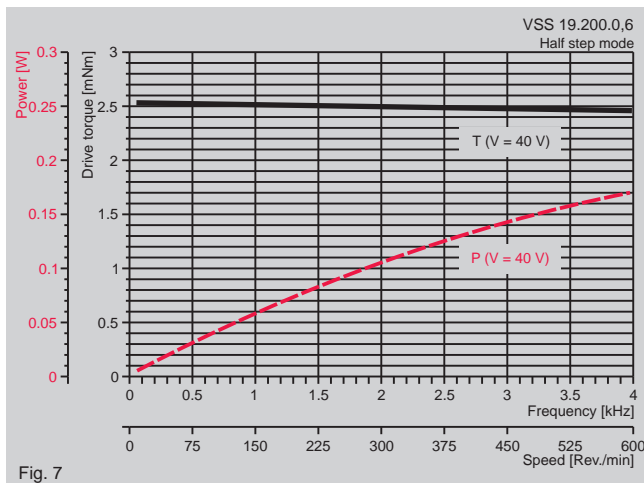

Fig. 7

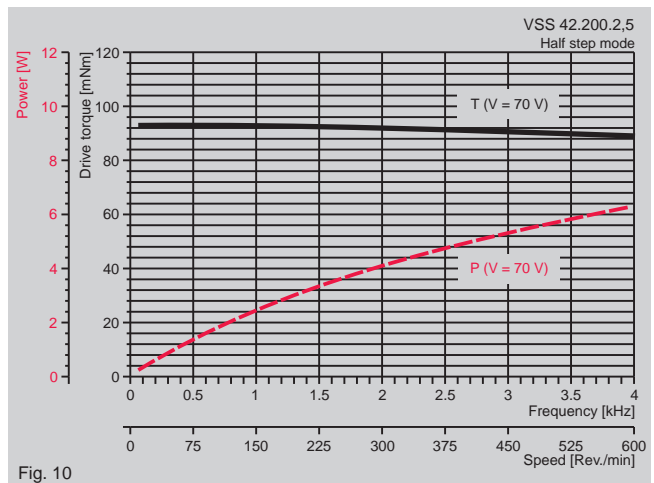

Fig. 10

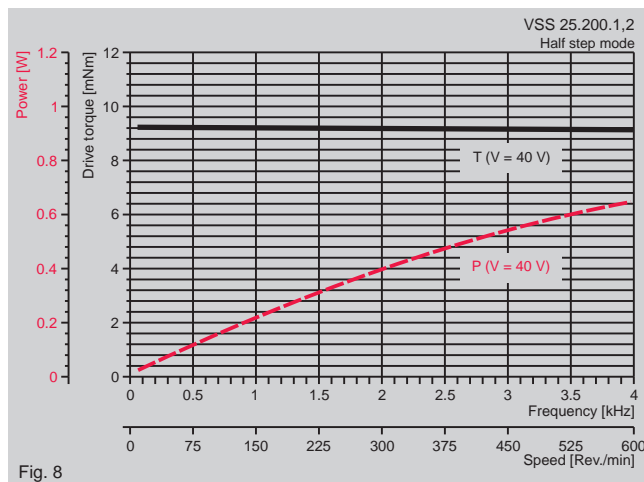

Fig. 8

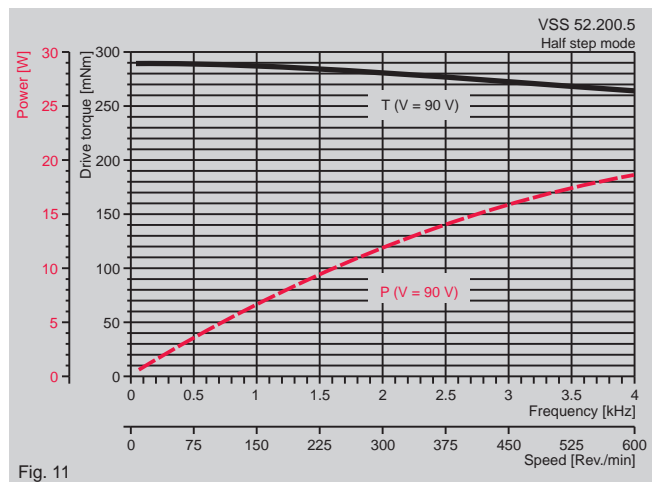

Fig. 11

VSH 65 – 125 / Torque and Power Characteristics

Torque Characteristics (T)

The curves correspond to the limit values of the drive torque as a function of the control pulses, for a motor voltage V.

The curves were plotted using a bipolar stepper motor driver in the half step mode.

Power Characteristics (P)

For each motor, the power at the motor shaft is plotted as a function of the frequency.

7 mNm ~ 1 oz-in

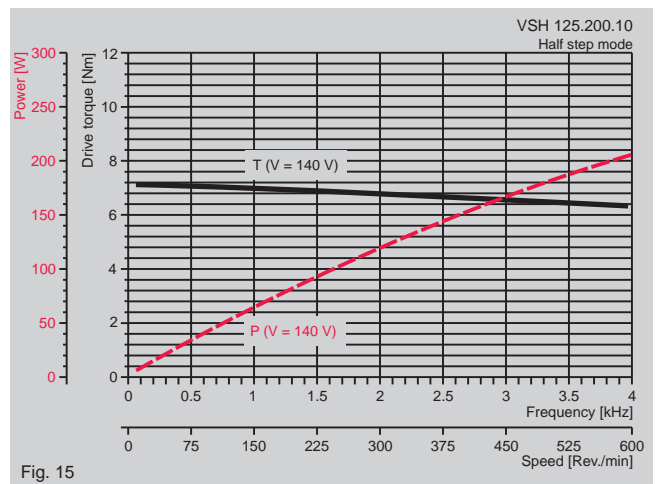
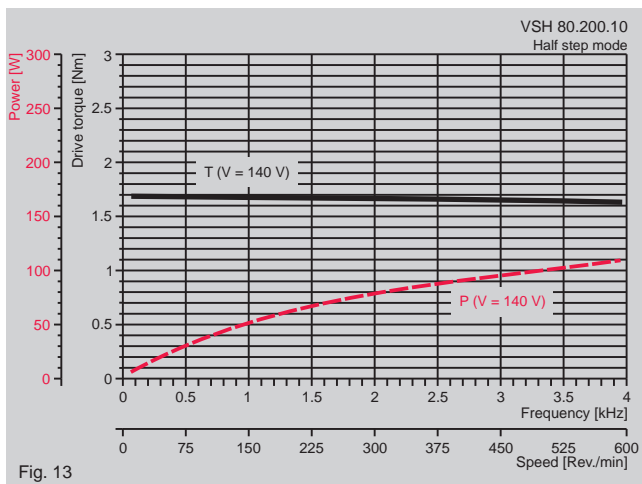
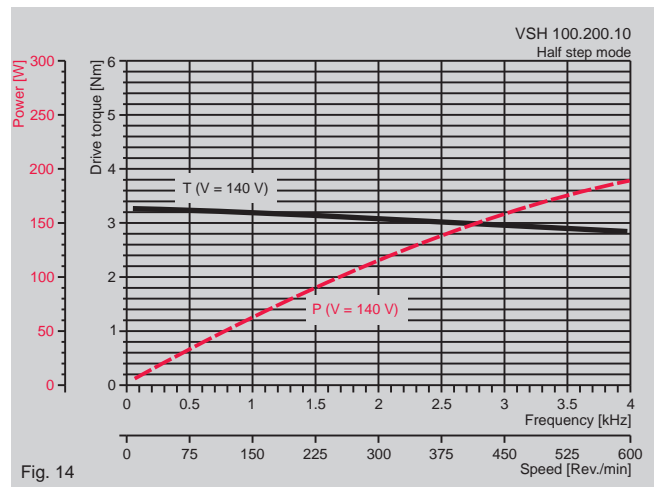
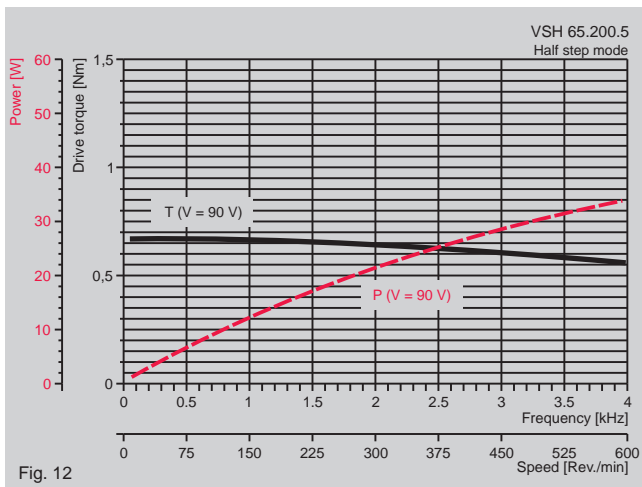

Electrical Connection

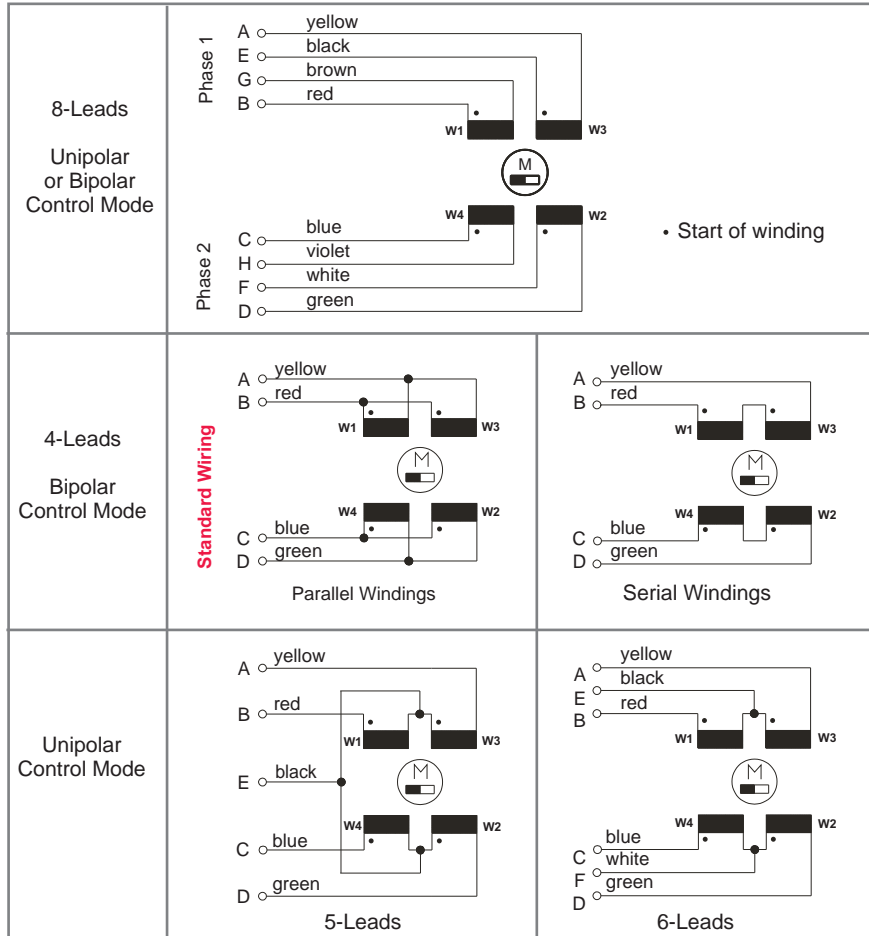

Rated Current

The motor rating plate has the rated phase current [A] as the last digits of the motor's type number.

Example: VSS 32.200.1,2

Motor type: VSS 32
Number of steps: 200
Rated current: 1.2 A

The **rated current** is defined as the phase current at full step operation, at bipolar control mode, with parallel connected windings (standard).

According to the connection mode, the motor windings receive different currents.

Therefore, for identical power dissipation in the motor, the **allowable phase current** is determined by the connection mode (see table below).

At **half-step or mini-step** operation of the control unit, the rated current is the r.m.s. value. The current tables in Phytron's power stage manuals show r.m.s. values.

Ordering Information

	VSS 42 . 200 . 2,5 - E - VGPL 42 / 20 - HV - KTC
Stepper Motor Series	VSS / VSH
Size	19 – 125
Steps/revolution	72 / 200 / 500 (depends on size)
Rated current	Amps/phase (bipolar, parallel windings)
Option E	Double shaft
Option VGPL	Low backlash gear / Reduction ratio
Environment	FV / HV / UHV / UHVC / Space
Options	Thermocouple KTC, Resistor Sensor Pt 100, Special: X

Allowable Phase Currents for Identical Power Dissipation			
Bipolar control mode Full step operation		Unipolar control mode Full step operation	
4-lead motor parallel windings	4-lead motor series windings	5-lead motor	6-lead motor
rated current	50 % of rated current	70.7 % of rated current	70.7 % of rated current

Any questions? Please contact us.